

# BIOLAN



## BIOLAN GREYWATER FILTER 125

*Instructions for installation, use and maintenance*

EN

Serial No.	
Assembler	Date of manufacture
Seller's stamp, signature and date of purchase	

70571500

05/2014

# BIOLAN

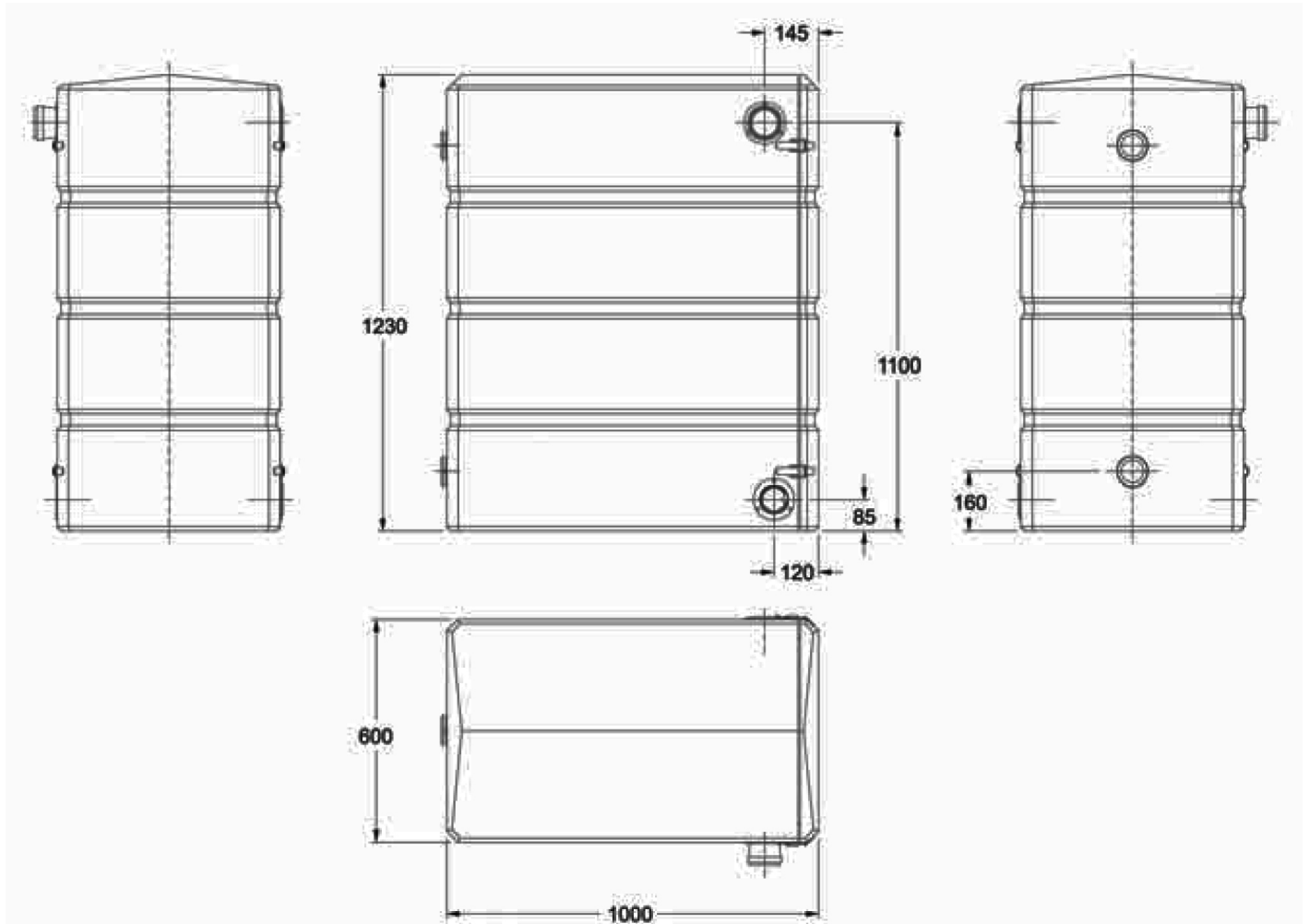

## BIOLAN GREYWATER FILTER 125

### *Instructions for installation, use and maintenance*

*The Biolan Greywater Filter 125 is a purifying unit for washing waters of one family, especially designed for weekend residences. Into the filter may be conducted washing waters and waters from sauna as well as dishwashing and laundry waters.*

*The Biolan Greywater Filter 125 shall be installed above the ground. The wastewater is conducted directly into the filter either by gravity or by pumping. The filter's treatment capacity is 500 litres per day, which in practice is sufficient for 1–5 persons.*

### Contents

Component list	EN-2
Component drawing	EN-2
1. Overview	EN-3
2. Planning and selecting the location	EN-3
2.1 Technical specifications	EN-3
2.2 To be located above the ground	EN-3
2.3 Location inside a residential building	EN-3
2.4 Conducting wastewater to the filter	EN-4
2.5 Discharge point for the wastewater	EN-4
3. Installation	EN-4
3.1 Connecting the inlet and outlet sewer pipes	EN-4
3.2 Putting the filter material in place	EN-4
3.3 Opening the air valves	EN-4
4. Use and maintenance	EN-4
4.1 Follow-up of the operation	EN-5
4.2 Changing the filter material	EN-5
4.3 Storing the filter over winter	EN-5
5. Possible malfunctions	EN-5
6. Disposal of the product	EN-5
Biolan accessories	EN-6
About the guarantee	EN-6



## Component list

	Part name	Number	Material
1	Body	571501	PE + urethane insulation
2	Service door	571502	PE + urethane insulation
3	Filter box, 10 pcs	571505	ABS plastic
4	Disk valve, 2 pcs	571506	PP
5	Sleeve pipe 250 x 75 mm	571510	PP
6	Inlet pipe end	571525	PP
7	Connecting flange	571511	PP
8	Lip seal, 4 pcs	573313	EPDM
9	Plug 75 mm, 8 pcs	571513	PP
10	Latch	571507	RST
11	Counter-piece	571508	RST

In addition to the components illustrated in the component drawing, the Greywater Filter 125 also includes:

	Disk valve body	573308	PP
	Attachment screw for flange	571521	RST
	Door seal 15 x 10 mm	573313	EPDM cell rubber
	Filling plug for urethane, 15 pcs	571524	PE
	Instructions for installation, use and maintenance	571528	Paper
	Filter material	5716	Package PE

Spare parts sales: dealers and the Biolan online shop at [www.biolan.fi](http://www.biolan.fi)

## Component drawing

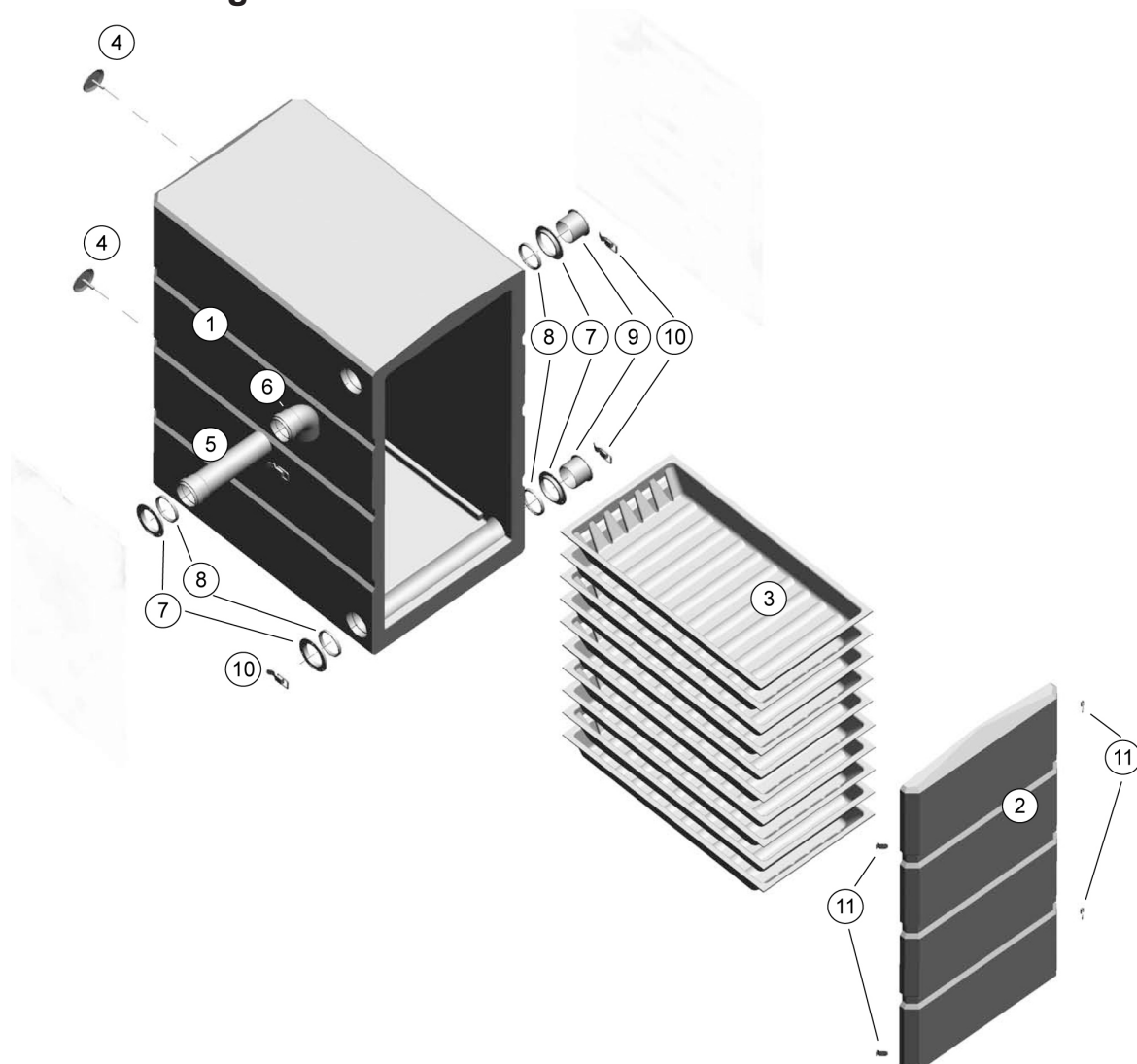

EN

# 1. Overview

The Biolan Greywater Filter 125 is a purifying unit for washing waters, especially designed for weekend residences. The filter purifies washing waters and waters from sauna as well as dish-washing and laundry waters in the property. The purifier meets the requirements of the State Council's decree (542/2003) on treatment of domestic wastewater outside the sewer systems of the waterworks.

Wastewater from a WC or dry toilet in the property must be conducted into a closed tank or treated otherwise in a due manner. Rain- or stormwater or drainage water from foundations must not be conducted into the filter. If installed in accordance with the instructions, the treatment capacity of the filter is about 500 litres per day, which in practice meets the need of washing water for 1–5 people. The treatment capacity of the filter material is good for about 100 days, after which it needs to be replaced in accordance with the maintenance instructions.

The operation of the filter is based on mechanical and biological filtration of wastewater. The dirt in the wastewater sticks to the organic filter material in the filter. The micro-organisms living on the surface of the filter material use the impurities as their nutrition.

The Greywater Filter 125 comprises ten filter boxes placed one on top of the other. The wastewater is conducted into the uppermost filter box. Inside the filter, wastewater flows by gravitation from one filter layer to the other through the openings in the end of the box.



In Finland, building a wastewater system or changing it always requires a building or action permission from the municipal building authority or a submission of notification of action. The building permission is applied by submitting a relevant plan.

## Installation example

Wastewater is conducted into the filter by gravity

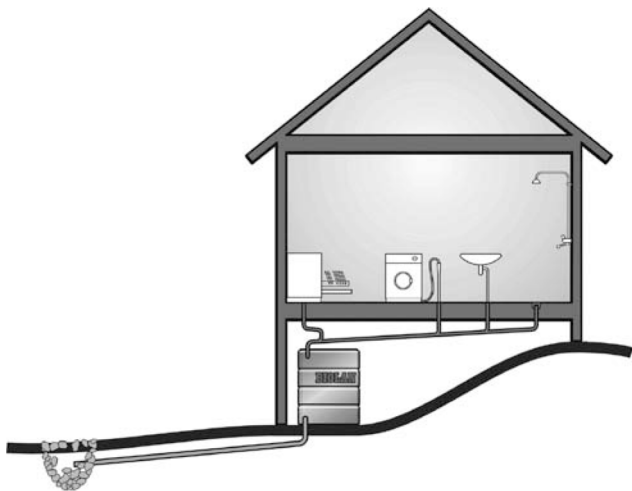

## Installation example

Wastewater is pumped into the filter

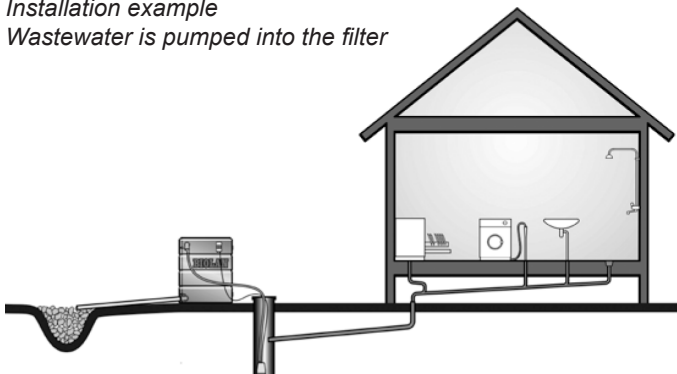

# 2. Planning and selecting the location

## 2.1 Technical specifications

- dimensions of one module: (width x height x depth) 600 x 1230 x 1000 mm
- pipe connectors for Ø 75 mm sewer pipes
- height difference of inlet and outlet connectors (height of fall): 1040 mm
- capacity: about 500 litres a day
- weight without filter material: about 75 kg

## 2.2 To be located above the ground

The Biolan Greywater Filter 125 shall be installed above the ground. Place the filter in a location where water will not gather, even when there is flooding. The filter can be installed out of doors without a cover. The unit is thermally insulated, which means it tolerates slight frost. If the filter is used in winter, it must, however, be equipped with the Biolan Heating Cable, which is available as an option, or the filter must be placed in a space, where the temperature stays above zero at all times.

The space required for use and maintenance must be taken into account when selecting the location. A free space, at least one metre deep, must be provided in front of the unit for changing the filter material. A sufficient space must also be provided at the sides and the rear of the unit to enable maintenance of the outlet connector for the sewer and the adjustment of the air valves in the rear wall. To ensure the supply of oxygen to the micro-organisms, the air exchange valves must not be covered or the air exchange must be arranged in some other way.

## 2.3 Location inside a residential building

Biolan Greywater Filters are primarily intended for installation out of doors. If you are planning to install the filter indoors or in close proximity to a residential building (for example, under the terrace), then some maintenance space with its own entrance should be provided. This space must also be provided with a floor well or an earthen floor for possible malfunctions.

The replacement air for the filter is taken from the end of the discharge pipe and the outlet air is conducted as sewer ventilation to the roof of the building. To avoid odour problems, the air valves of the unit must be kept closed. The outlet air can also be conducted through the upper air valve in the rear wall of the filter into a separate outlet air channel. If the unit is installed indoors, the outlet air channel shall be fitted with an aspirator that maintains a slight negative pressure inside the filter.



Whenever the Greywater Filter is located in a warm space in a residential building, or in close proximity to a residential building, the correct installation must always be verified with the expert in charge of planning the HVAC system for the building.

## 2.4 Conducting wastewater to the filter

The wastewater is conducted directly to the filter alternatively by gravity, by flow drainage or by a pump well. To ensure an even distribution, the inlet pipe should be provided with a straight 80cm-long part before the branch sleeve (part 7), that reduces turbulence of the incoming water flow.

If you intend to utilise existing septic tanks during pumping, these should be in good condition and hermetically sealed. The operation of the pump must be sequenced using a timer so that during one sequence the pump will feed at maximum 20 litres of wastewater to the filter. The interval between the sequences must be at least 10 minutes. The Biolan Timer, the Submersible Pump and the Pump Well are available as an option.

## 2.5 Discharge point for the wastewater

Conduct the treated wastewater to a suitable discharge point, for example a stone pocket or an open ditch. When planning, bear in mind that the discharge of wastewater should be unobstructed even when the level of the surface water or groundwater is high. If you route the water to an open ditch, provide the end of the pipe with a flap or a net to prevent rodents or other small animals from gaining access.

## 3. Installation

Place the filter on a firm and even surface that is not susceptible to frost, such as, for example, a bed of gravel or crushed stone or a cast concrete slab. The filter must be in a horizontal position both lengthwise and laterally to allow the wastewater to flow smoothly over the entire cleaning area of the filter material.

## 3.1 Connecting the inlet and outlet sewer pipes

While installing gravity flow sewers, a sufficient gradient (of at least 1-1,5 %) needs to be provided to allow the wastewater to flow without obstruction from the sewer outlet of the house all the way to the discharge point.

There are inlet and outlet connectors for 75 mm sewer pipes on both sides of the filter. Depending on the requirements of the location, the pipes can be installed on either side. Connect the sewer pipe coming from the building to the inlet connector at upper edge of the filter. Connect the discharge sewer pipe to the outlet connector at its lower edge. Close the unused openings using plugs (product number 571513).

If the filter will be used in winter, the inlet sewer must be insulated. Whether also the outlet sewer needs to be insulated, shall be considered case by case.

## 3.2 Putting the filter material in place

The filter material is packed in plastic bags for transportation. Remove the plastic bags. Rip the filter material loose and spread it evenly across the boxes by tapping it gently. Resulting from the packaging method, the bags may contain excessive amount of filter material. The filling grade of the box is suitable when the surface of the filter material lies about 2 cm lower than the brim of the box. Finally, draw the filter material about 5 cm to the rear from the V-openings in the discharge end of the box.

The filter material boxes are identical, but their direction should be observed – in the uppermost box water flows towards the rear wall, in the next box it flows towards the service door etc. In the lowermost box water flows towards the rear wall, from where it falls along the shaped bottom into the discharge sewer.

## 3.3 Opening the air valves

The operation of the filter is based on activity of the micro-organisms. These micro-organisms need oxygen to survive, and therefore, it is vital to provide the filter with sufficient air exchange. There are two adjustable disk valves for air exchange in the rear wall of the modules. Set both disk valves of the module about 10–20 mm ajar for the summer. In winter keep the valves only slightly ajar (about 5–10 mm). If you have realised the air exchange by means of sewer ventilation, keep the air valves completely closed to avoid odour problems (see point 2.3).

## 4. Use and maintenance

The unit must be used and maintained in accordance with the instructions, and its operation must be monitored regularly. Maintenance of the wastewater system also involves maintenance of the pump well and the septic tanks, if provided.

Into the filter can be conducted washing waters and waters from sauna as well as dishwashing and laundry waters. The filter tolerates a small amount of anti-bacterial or chlorine-based agents that are commonly used for cleaning. Follow the dosing instructions issued by the manufacturer of the detergent.

Wastewater from a WC or a dry toilet, rain water or stormwater, or drain water from foundations must not be conducted into the filter. Toxic chemicals or substances that contain such chemicals, which can kill the micro-organisms that clean the wastewater, such as drain openers, paints, oils or solvents, must not be conducted into the filter. Harmful chemicals can be identified from the markings on their packaging:

Toxic



Corrosive



Hazardous to the environment



Inflammable



Oxidizing



## 4.1 Follow-up of the operation

Check the operation of the filter at least twice during every operating season. A well-functioning filter does not give off a strong smell, the filter material in it remains moist and the exiting water is clear and odourless and does not contain a significant amount of solid matter.

### Check that

1. wastewater is flowing smoothly in both modules through all the openings of the box
2. the filter material has been drawn to a distance of about 5 cm from the openings in the discharge end of the box
3. the air exchange valves are in the correct position and the air is flowing without obstruction
4. the visible connections of the sewers are in order
5. the purified wastewater is flowing freely out of the filter

## 4.2 Changing the filter material

Normally, the filter material of the filter must be replaced every 100 days of operation. Only material, specially intended for use in the Biolan filters, shall be used as filter material.. Biolan Oy does not guarantee the purification capacity of the unit if any other filter material is used.

1. Change the filter material of all boxes at the same time.
2. Open the service door of the filter and draw out the filter material boxes keeping them in a level position.
3. Empty the filter material into the compost or use it as cover soil for ornamental plants.
4. Refill the boxes with new filter material. Rip the filter material loose and spread it evenly across the box by tapping it gently. Finally, draw the filter material about 5 cm to the rear from the V-openings.
5. Check the inlet and outlet connectors for wastewater and clean them.
6. Return the boxes filled with filter material to the filter unit. The filter material boxes are identical, but their direction should be observed – in the uppermost box water flows towards the rear wall, in the next box it flows towards the service door etc. In the lowermost box water flows towards the rear wall, from where it falls along the shaped bottom into the discharge sewer.
7. Make sure that the unit is on a level both lengthwise and laterally so that wastewater will be evenly divided into both modules and flows smoothly from one filter box to the other.
8. Close the service doors of the filter carefully.
9. Write down the service measures that were taken.

## 4.3 Storing the filter over winter

Leave the filter material boxes inside the filter. Freezing of the filter material does not damage the unit. If the filter material is still frozen when the operation starts in spring, thaw it by pouring warm, clear water through the filter.

## 5. Possible malfunctions

### The filter material box remains filled with water

The filter material box shall drain off between the times of operation. If this is not the case, the filter material may be clogged.

1. Make sure that the filter material has been drawn to a distance of about 5 cm from the openings in the discharge end of the box. As necessary, push the filter material slightly to the rear.
2. Check the age of the filter material. In heavy and continuous use, the filter material may get clogged already during the first 100 days of operation. Replace the filter material, if necessary.

### Flies in the filter

The air openings of the Greywater Filter are fitted with fly nets of small mesh size. Despite the nets, small flies or gnats may sometimes establish themselves in the filter. If flies are interfering with the filter, you can do away with them using a pyrethrin-based insecticide. Consult your local garden centre to select a suitable product.

## 6. Disposal of the product

The raw materials used are presented in the component list (see page 4). Dispose of each part as prescribed. Always follow the regional and collecting-point-specific instructions.



PE = polyethylene

to collection of energy waste or recycling of plastic



PP = polypropylene

to collection of energy waste or recycling of plastic

RST = stainless steel

to recycling of metal

Paper

to recycling of paper

EN

# Biolan accessories

Availability varies from country to country. Consult your local dealer for details.

## Biolan Filter Material

The filter material for the Greywater Filter is made of Warnstorfia or Calliergon moss collected in connection with restoration of lakes. The moss, which has grown under conditions rich in nutrients, makes an efficient and natural material for purification of waste water.

Product no. 70574100,  
HVAC number 3623604



## Biolan Sampling Well

The Biolan Sampling Well is an accessory that makes it easier to supervise the operation of the wastewater treatment system, and enables reliable sampling of the wastewater. It is also suitable for an underdrain well or a pump well.

Product no. 5713,  
HVAC code 3623605Biolan



## Pumping Package

The Biolan Pumping Package is an accessory for places where gravity flow drainage of the wastewater to the filter is not possible. By means of the Timer the wastewater is fed from the Pump Well to the filter in suitable doses. The Pumping Package comprises three parts: Timer, Submersible Pump and Pump Well. The parts are also available separately.

Product no. 70577300,  
HVAC code 3623606

Comprises:

Timer 70577000,  
HVAC number 3623608

Submersible pump 70577100,  
HVAC number 3623609

Pump Well 70577200,  
HVAC number 3623607



## About the guarantee

**The Biolan Greywater Filter 125 is guaranteed for five years**

1. The guarantee is valid from the date of purchase and covers possible defects in material and workmanship. The guarantee does not cover any indirect damage.
2. Biolan Oy retains the right to decide about repairing or replacing damaged parts at its discretion.
3. Any damage resulting from careless or forcible handling of the device, from failure to observe the operating instructions, or from normal wear, will not be covered by this guarantee.
4. The buyer must present a duly filled out guarantee certificate or a detailed purchase receipt when submitting claims under the guarantee.

For matters related to the guarantee, please consult Biolan Oy directly.

# BIOLAN

Biolan Oy  
P.O. Box 2, FI-27501 KAUTTUA  
Tel. +358 2 5491 600  
www.biolan.fi